



SPECIFICATION FOR T STYLE ENCLOSURE

- 1) **Material** :- All lids, base and body are manufactured in Mild Steel. For thicknesses of lids base and body please refer to table below.
- 2) **Preparation** :- This enclosure is completely degreased and then has an iron phosphate treatment. Paint thickness onto of this is to a minimum of 70microns
- 3) **Type of paint** :- Epoxy polyester paint
- 4) **Colour** :-Pebble Grey RAL 7032
- 5) **Characteristics of paint material** :- Exhibits excellent mechanical strength & corrosion resistance . It is also chemically resistant to many acids , oils & solvents .
- 6) **Environmental use** :- These cases are suitable for indoor use . Can obtain IP54 versions which are suitable for outdoor applications
- 7) **Mechanical** :- These cases are designed to be floor mounted .These enclosure are not designed to withstand large amounts of vibration or shock loads .
- 8) **IP rating** :- All our standard range of T style cases are rated at IP 22 protection . This range of cases can be modified to increase the IP rating to the customer requirements .

TABLE GIVING DETAILS OF PANEL THICKNESS FOR T RANGE OF ENCLOSURES

P DESIGNATION	THK OF SIDE PANELS (mm)	THK OF LID (mm)	THK OF BASE CHANNEL(mm)
T3	1.5	1.5	3.0
T4	1.5	1.5	3.0
T5	1.5	1.5	3.0

Note:- Please refer to Birmingham Transformers Drawing No BTD-00057 for overall dimensions.

Standard specification for P range of enclosures .

Photograph of T style Enclosure



PROJECTION

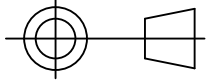

BIRMINGHAM TRANSFORMERS LTD.
COPYRIGHT

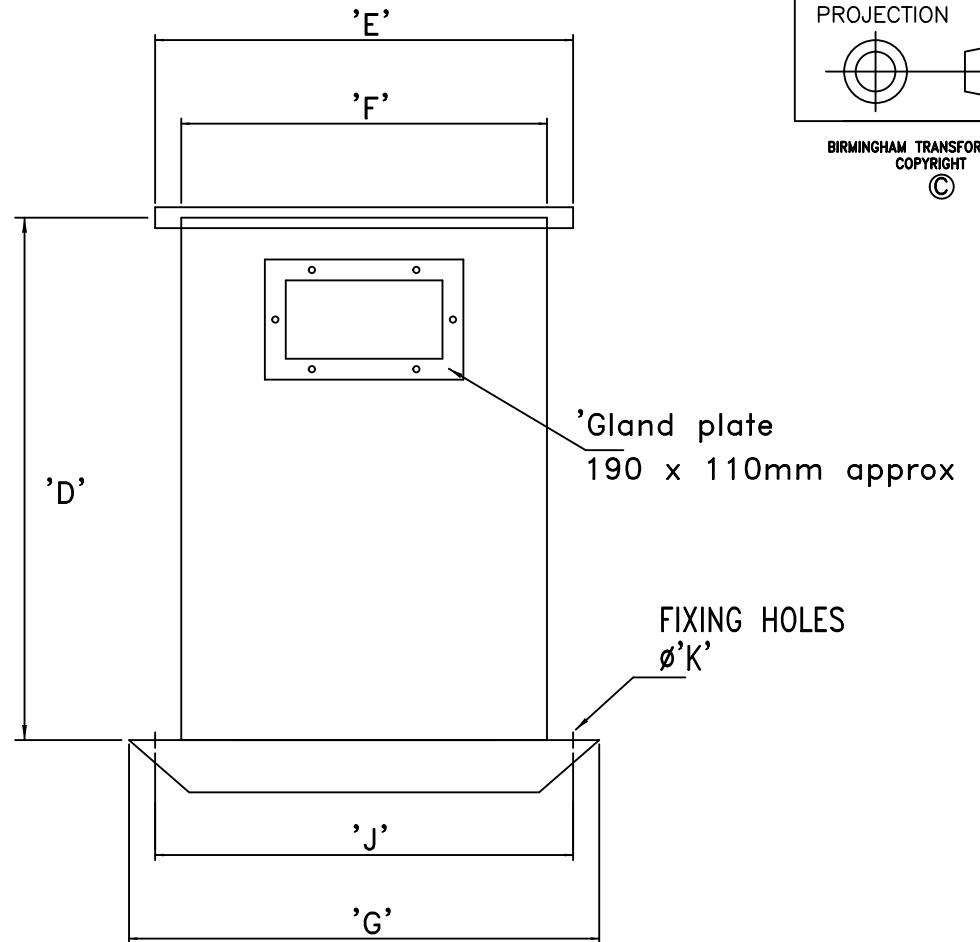
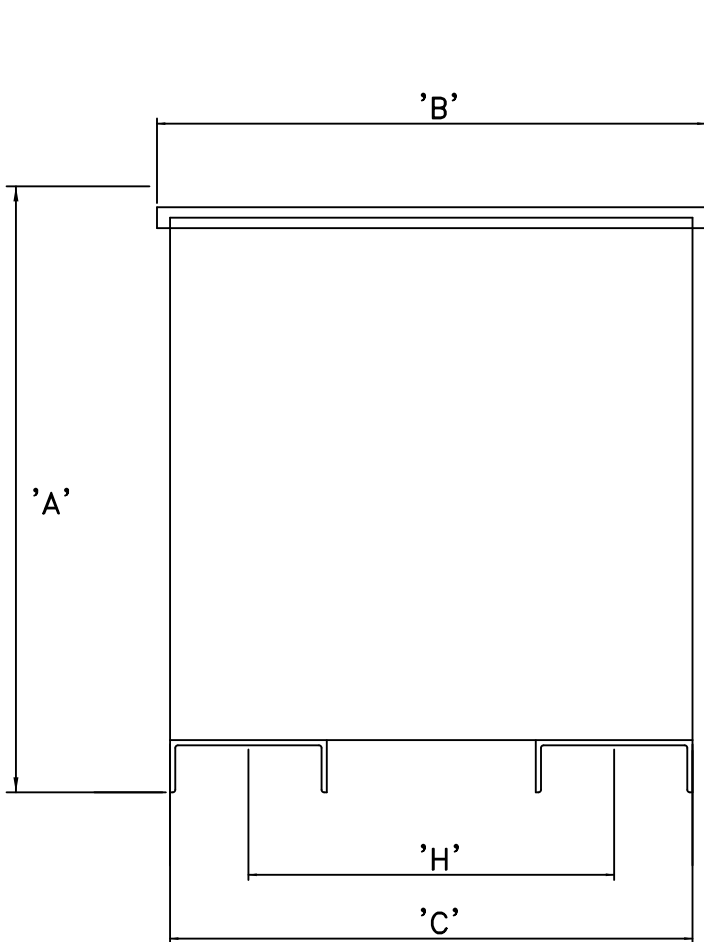

ENCLOSURE	A	B	C	D	E	F	G	H	J	K	wgt (kg)
T3	567	525	500	500	400	350	450	350/ 168	400	13dia	20
T4	665	625	600	600	454	400	500	450/ 188	450	13dia	27
T5	825	770	740	760	535	485	600	650/ 228	550	13dia	50

ISSUE	DESCRIPTION	APPROVED	DATE	TITLE	DRAWN	CHECKED	APPROVED	DATE
2	Col 'L' removed from table	S.DAYUS	6/4/2016	Overall dimensions of T Style Cases. and approx weights	S.D.			28/01/14
					BIRMINGHAM TRANSFORMERS LTD. Uni6 - Weston Works - Weston Lane Birmingham B11 3RP Tel no 0121-7645600 Fax No 0121-7645551 E-mail - sales@birminghamtransformers.co.uk			